

**Orange Coast Property Services****South Coast Property Services****(949) 454-7900 -- (760) 585-2355**

Doc #: COMMERCIAL SAMPLE Inspector: Certified Inspector
Date: 9/27/2022
Address: 123 Main Street
Any Town CA
Client Name: Mr. Buyer

We attempt to give the client a comprehensive, clear-cut, unbiased view of the building. The purpose of this inspection is to identify 'MAJOR' problems associated with the property being purchased or sold, although minor items may also be mentioned. Areas, which may be of concern to us, may not be of concern to the client and some items, which may be of concern to the client, may be considered minor to us. Therefore, it is advisable to read the entire report. Where repairs or replacements are suggested, we recommend licensed professionals in that field be called upon to make those repairs. We can perform verification of repairs to ensure repairs or corrections were made and also advise the client to obtain all paperwork from professionals concerning the work performed. These professionals will be happy to provide you with written statements concerning their work. We further recommend maintaining all paperwork on repairs for future reference. FUTURE FAILURE: Items in the building can and do experience failure without prior indications. This report is a snap shot of the condition of the building at the time of inspection. We cannot determine if or when an item will experience failure. Therefore, we cannot be held responsible for future failure. Carbon monoxide and smoke detectors have been proven to save lives. Client is advised to install carbon monoxide and smoke detectors if not already present in building. Suggest consulting with your local municipality and manufacture specifications as to the proper location and installation of these units.



TABLE OF CONTENTS

SECTION	PAGE
Cover Page	1
Table of Contents	2
Intro Page	3
1 EXTERIOR	4
2 ROOF	5
3 HEATING AND AIR CONDITIONING	6
4 PLUMBING	7
5 ELECTRICAL	7
6 KITCHEN	8
7 HALF BATH	9
8 ENTRY	10
9(A) CONFERENCE ROOM	10
9(B) FRONT RIGHT OFFICE	11
9(C) MIDDLE RIGHT OFFICE	11
9(D) CUBICLES	12
9(E) FRONT OFFICE	12
9(F) COPY ROOM	12
10 HALL	13

This report may contain digital photographs of some items and components. These images are for your convenience only and do not represent all items or components that may be deficient. ALL DEFECTS ARE NOT PHOTOGRAPHED; the entire written report must be reviewed.

Please take the time to analyze the following pages contained herein. This is your complete inspection report and must be reviewed carefully. Below is an index of the ratings used in this report.

S: The items inspected appeared in serviceable condition at time of inspection.

SERVICEABLE: The items inspected appeared to function normally at time of inspection.

N: The item was not present at the time of inspection.

Operable: The item inspected operated properly at time of inspection.

GENERAL CONDITIONS

Structure Type:

Levels: One story structure.

Lot Type: Built on a flat lot.

Estimated Age: 40 to 50 years.

Weather Conditions: Clear.

Occupancy: Building was occupied at the time of inspection.

Viewed From: Front door.

EXTERIOR

Our exterior evaluation is visual in nature and is based on our experience and understanding of common building methods and materials. Our review does not take into consideration the normal wear associated with virtually all properties. As per our inspection agreement, we do not inspect for termites, dry rot, fungus, or other wood destroying insects or organisms as that is a specially licensed trade. If deterioration and/or damage is noted on the exterior or interior of this building, we suggest further review of the termite report. Regardless of the age of the building, we recommend inquiring about any permits and inspection reports with final signatures for the building and for any changes, remodels or additions that may have been made to the building.

Driveway:

Asphalt

Walkways:

Concrete

Siding:

Stucco

Windows & Frames:

Metal

Foundation:

Concrete Slab Construction

Step #	Component	Comment
1.0	Parking Lot	Condition:.. Cracked asphalt noted.
1.1	Walkways/Stairs	Condition:.. Common cracks and chipped concrete noted.
1.2	Walls/Fence/ Gates	N.
1.3	Siding	Condition:.. Damaged areas of stucco noted. Common cracks noted.



1.4	Trim	N.
1.5	Window Frames	S.
1.6	Electrical	S.
1.7	Gutters/ Downspouts	N.
1.8	Sprinklers	N.
1.9	Lot Grade/Drainage	Structure is built on a flat lot. Grade at the foundation appears to be adequate.

- 1.10 Gas Meter **Condition: Unable to locate, suggest further review with the seller.**
- 1.11 Foundation **S.**
- 1.12 Other Comments **Condition: This is not an ADA compliance inspection at that is beyond the scope of this inspection.**

ROOF

Our evaluation of the roof is to determine if portions are missing and/or deteriorating and, therefore, subject to possible leaking. Portions of underlayment and decking are hidden from view and cannot be evaluated by our visual inspection; therefore, our review is not a guarantee against roof leaks nor a certification.

Roof Type: Sloped	Roof Material Type: Rolled Roofing	Method Used to Inspect Roof: Walked roof
-----------------------------	--	--

Step #	Component	Comment
2.0	Flashing	
2.1	Condition	Condition. Roof shows normal wear for its age and type. Evidence of ponding noted. This condition indicates improper drainage. Deteriorated composition noted. We suggest that the maintenance efforts be made in the few areas where roofing materials are damaged or missing. Suggest consulting a licensed roofer for further review.





- 2.2 Skylights N.
- 2.3 Roof Penetrations S.

HEATING AND AIR CONDITIONING

Our evaluation of major systems is both visual and functional provided power and/or fuel is supplied to the component. Identifying or testing for the presence of asbestos, radon, lead based products, or any other potentially hazardous materials is not within the scope of this report. If the structure was built prior to 1978, testing or additional inspection(s) by a specialist may be warranted. Judging the sufficiency of water flow in plumbing or the cooling efficiency of air conditioning is a subjective evaluation, therefore, we only note a poor condition if, in the inspector's opinion, the adequacy seems to be less than normal. We urge you to evaluate these systems prior to closing.

The adequacy, efficiency or even distribution of air throughout the building cannot be addressed by a visual inspection. The inspector does not perform pressurization or smoke tests on the duct system. As a result, no representation is made regarding the duct systems compliance with Title 24 of the California Energy Efficiency Standards for Residential and Nonresidential Buildings. Normal servicing and maintenance is recommended on a yearly basis to ensure that duct leakage is held to a minimum.

DISMANTLING AND/OR EXTENSIVE INSPECTION OF INTERNAL COMPONENTS OF ANY APPLIANACE, INCLUDING HEATERS AND HEAT EXCHANGERS, IS BEYOND THE SCOPE OF THIS REPORT. THE LOCAL UTILITY COMPANY WILL CONDUCT SUCH AN INSPECTION UPON REQUEST.

Heating System Location:	Heating System Type:	Number of Heating Systems:
Roof	Heat Packs	One

Step #	Component	Comment
--------	-----------	---------

3.0 Heating **Condition: Unable to test per request of tenants.**



3.1 Venting **Condition: Unable to test.**

3.2 Air Conditioning **Serviceable. Compressor is located on the roof.**

3.3 Thermostat **Operable. Located in the several offices.**

3.4 Ducting **Electronic damper system noted, not tested as it is beyond the scope of this inspection.**

PLUMBING

Plumbing Water Distribution

Type:

Copper

Step #	Component	Comment
4.0	Main Shut-off	Condition: Unable to locate the shut-off valve, suggest further review with the seller/association.
4.1	Drain/Waste Vents	S.

ELECTRICAL

Service Amperage:

Unable to determine

Step #	Component	Comment
5.0	Service Entrance	Service entrance is underground.
5.1	Main Panel	Serviceable. Main panel is located in the electric room.

5.2 Sub Panel **Serviceable. Sub panel is located next to the main panel.**

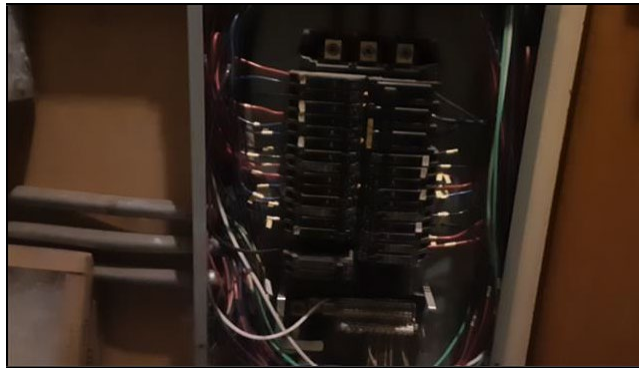

5.3 Overload Protection **Overload protection is provided by breakers.**

5.4 Main Disconnect **Condition:. Unable to determine which breaker services this unit, suggest further review with the seller/association.**

5.5 Wiring **Low branch circuit wiring is copper.**

5.6 Futures **Futures are provided for possible expansion.**

KITCHEN

The kitchen inspection is a combination of visual and functional. Shut-off valves and angle stops under sinks are not turned or tested during the inspection due to the possibility of causing leaks. All shut-off valves or angle stops should be turned regularly by the building owner to ensure free movement in case of emergency. Appliances are operated, if power is supplied. Calibrations to cooking systems and oven self-cleaning cycle and timers are not evaluated nor life expectancies given to dishwashers. NOTE: Dishwashers can fail at any time due to their complexity. Our review is to determine if the system is free of leaks and excessive corrosion.

Floors:

Tile

Countertops:

Granite

Step #	Component	Comment
6.0	Floors	S.
6.1	Walls	S.
6.2	Ceiling	S.
6.3	Doors	N.
6.4	Windows	N.
6.5	Screens	N.
6.6	Cabinets	Condition:. Some doors do not stay closed.
6.7	Countertops	S.

6.8 (1) Electrical

Condition: Loose outlet noted.

6.8 (2) Electrical

Condition: Ground fault circuit interrupters are provided for safety. We suggest periodic testing to ensure proper working order.

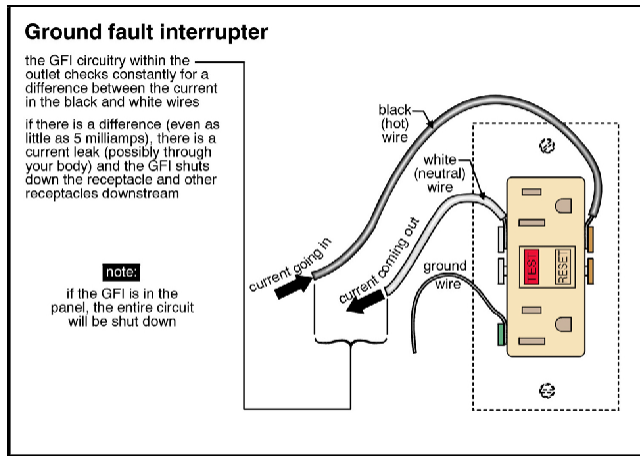

GFCI

6.9 Sinks

Serviceable. Stainless steel.

6.10 Faucets

S.

6.11 Traps/Drains/Supply

S.

6.12 Disposal

Serviceable. Make: ISE.

HALF BATH

Our focus in bathrooms is directed at identifying visible water damage and/or visible plumbing problems. Shut-off valves and angle stops under bathroom sinks and toilets are not turned or tested during the inspection due to the possibility of causing leaks. All shut-off valves or angle stops should be turned regularly by the building owner to ensure free movement in case of emergency.

Floors:

Tile

Step #	Component	Comment
7.0	Floors	S.
7.1	Walls	S.
7.2	Ceiling	S.
7.3	Doors	S.
7.4	Windows	N.
7.5	Screens	N.

7.6	Electrical	Serviceable. Ground fault circuit interrupter is provided for safety. We suggest periodic testing to ensure proper working order.
7.7	Exhaust Fan	S.
7.8	Heating	S.
7.9	Sink	S.
7.10	Sink Faucet	S.
7.11	Traps/Drains/Supply	S.
7.12	Toilet	S.
7.13	Counter/Cabinets	N.

ENTRY

Our interior review is visual and evaluated with similar aged building in mind. Cosmetic considerations and minor flaws can be overlooked, thus we suggest you double-check these items, if concerned. NOTE: AS POINTED OUT IN THE INSPECTION AGREEMENT, MATERIALS REGULARLY USED IN RESIDENTIAL CONSTRUCTION MAY CONTAIN POTENTIALLY HAZARDOUS SUBSTANCES SUCH AS ASBESTOS AND FORMALDEHYDE. OUR REPORT WILL NOT IDENTIFY THESE SUBSTANCES SINCE LABORATORY TESTING IS NECESSARY TO DETECT THEIR PRESENCE.

Floors:

Tile

Step #	Component	Comment
8.0	Floors	S.
8.1	Walls	S.
8.2	Ceiling	S.
8.3	Doors	S.
8.4	Windows	S.
8.5	Screens	N.
8.6	Electrical	S.

CONFERENCE ROOM

Step #	Component	Comment
9.0.A	Floors	S.

9.1.A	Walls	S.
9.2.A	Ceiling	S.
9.3.A	Doors	S.
9.4.A	Windows	S.
9.5.A	Screens	N.
9.6.A	Electrical	S.

FRONT RIGHT OFFICE

Step #	Component	Comment
9.0.B	Floors	S.
9.1.B	Walls	S.
9.2.B	Ceiling	S.
9.3.B	Doors	S.
9.4.B	Windows	S.
9.5.B	Screens	N.
9.6.B	Electrical	S.

MIDDLE RIGHT OFFICE

Step #	Component	Comment
9.0.C	Floors	S.
9.1.C	Walls	S.
9.2.C	Ceiling	S.
9.3.C	Doors	S.
9.4.C	Windows	S.
9.5.C	Screens	N.
9.6.C	Electrical	S.

CUBICLES

Step #	Component	Comment
9.0.D	Floors	S.
9.1.D	Walls	S.
9.2.D	Ceiling	S.
9.3.D	Doors	Condition:. Rough operation noted at the slider.
9.4.D	Windows	N.
9.5.D	Screens	Condition:. Slider is not present.
9.6.D	Electrical	Condition:. Inoperable lights noted.

FRONT OFFICE

Step #	Component	Comment
9.0.E	Floors	S.
9.1.E	Walls	Condition:. Cut section noted.



9.2.E	Ceiling	S.
9.3.E	Doors	S.
9.4.E	Windows	S.
9.5.E	Screens	N.
9.6.E	Electrical	S.

COPY ROOM

Step #	Component	Comment
--------	-----------	---------

9.0.F	Floors	S.
9.1.F	Walls	S.
9.2.F	Ceiling	S.
9.3.F	Doors	N.
9.4.F	Windows	N.
9.5.F	Screens	N.
9.6.F	Electrical	S.

HALL

Step #	Component	Comment
10.0	Floors	S.
10.1	Walls	S.
10.2	Ceiling	Condition:.. Water stains noted in rear storage closet, roof above.
		
10.3	Doors	N.
10.4	Windows	N.
10.5	Screens	N.
10.6	Electrical	Condition:.. One inoperable light noted.